

Montageanleitung Montagehandleiding Installation instructions

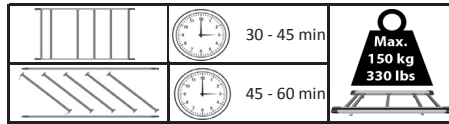

Mercedes Vito - L2H1 (3200) 2800 x 1500

Montagematerial Montagemateriaal Mounting material		
	L2H1 (3000)	
	LC 02 007	2x
	LC 02 016	4x
	LC 02 003	2x
	LC 02 023	4x
	M8	12x
	M8	22x
	M8	10x
	M8(x24)	10x
	M6x16	6x
	M6(x18)	6x
	M6	6x
	30x5	900mm

Werkzeuge Gereedschap Tools	
	10 + 13

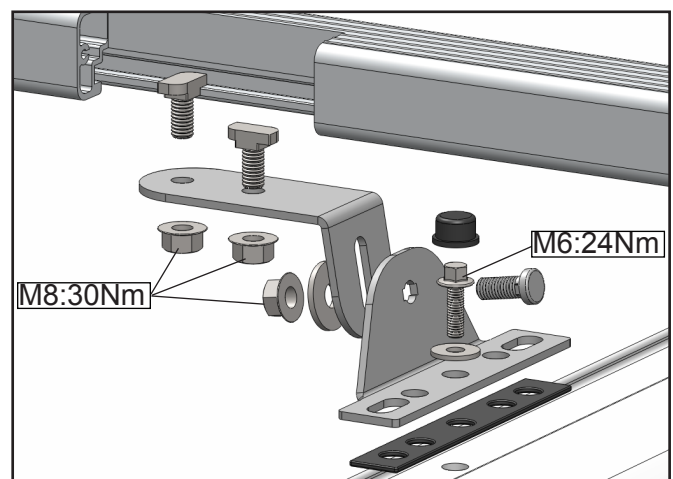
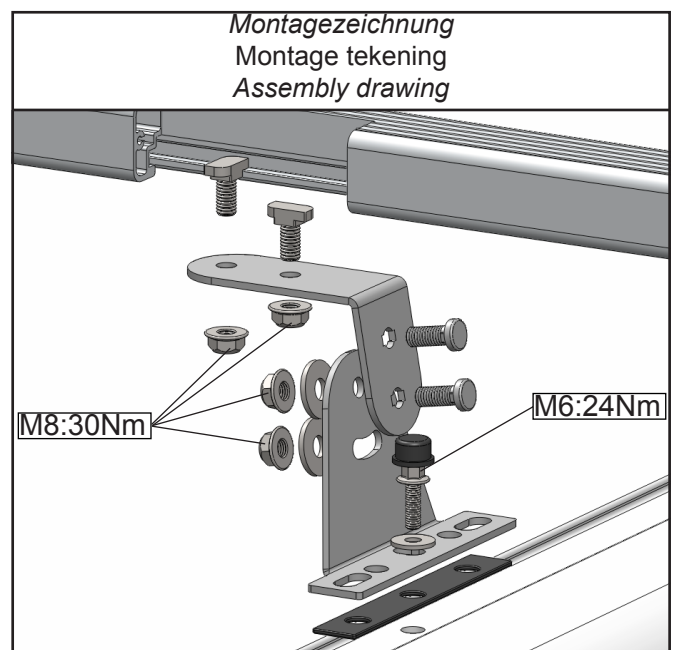

**Alle Schrauben und Muttern sollten jederzeit auf deren Anzugsdrehmoment überprüft werden !
Alle bouten en moeren dienen ten alle tijden te worden gecontroleerd op hun aandraaimoment !
All bolts and nuts should be checked at all times for their torque !**

